



Learning Analytics Dashboards for Assessing Remote Labs Users' Work: A Case Study with VISIR-DB

Vanessa Serrano^{1,2}  · Jordi Cuadros¹ · Laura Fernández-Ruano¹ ·
Javier García-Zubía³ · Unai Hernández-Jayo³ · Francesc Lluch¹

Accepted: 18 June 2024 / Published online: 4 July 2024
© The Author(s) 2024

Abstract

In science and engineering education, remote laboratories are designed to bring ubiquity to experimental scenarios, by having real laboratories operated through the Internet. Despite that remote laboratories enable the collection of students' work data, the educational use of these data is still underdeveloped. Learning analytics dashboards are common tools to present and analyze educational data to provide indicators to understand learning processes. This paper presents how data from remote labs, such as Virtual Instruments Systems In Reality (VISIR), can be analyzed through a learning analytics dashboard to help instructors provide better feedback to their pupils. Visualizations to study the use of the VISIR, to assess students' performance in a particular activity and to facilitate the assisted assessment of students are introduced to the VISIR dashboard (VISIR-DB). These visualizations include a new recodification of circuits that keeps the fragment being measured, in order to better identify student's intention. VISIR-DB also incorporates functions to check a priori steps in the resolution process and/or potential errors (observation items), and logical combinations of them to grade students' performance according to the expected outcomes (assessment milestones). Both work indicators, observation items and assessment milestones, can be defined in activity-specific text files and allow for checking the circuit as coded by the interface, the conceptual circuit it represents, its components, parameters, and measurement result. Main results in the use of VISIR for learning DC circuits course show that students mainly use VISIR when indicated by instructors and a great variability regarding to time of use and number of experiments performed. For the particular assessment activity, VISIR-DB helps to easily detect that there is a significant number of students that did not achieved any of the expected tasks. Additionally, it helps to identify students that still make a huge number of errors at the end of the course. Appropriate interventions can be taken from here.

Keywords Data mining · Learning analytics · Learning analytics dashboard · Remote laboratory · VISIR

1 Introduction

In the Educational Data Science context, the main goal of Learning Analytics (LA) is to approach educational research through data to improve teaching and learning; nevertheless, in LA the focus is more educational than technological and model development is not a priority (Romero & Ventura, 2020). The First International Conference on Learning Analytics and Knowledge (LAK) defined LA as "the measurement, collection, analysis and reporting of data about learners and their contexts, for the purposes of understanding and optimizing learning and the environments in which it occurs" (Conole et al., 2011, as cited in Siemens & Long, 2011). Since then, the growth of this discipline has been exponential in terms of the number of published papers (McFarland et al., 2021).

A LA analysis could be carried out at different levels (Fischer et al., 2020), from a macro institutional level to a micro where the time component is shorter. At the micro level, the analysis of the collected logs, where this contribution fits, can be used to identify both learning components and abilities, to assess acquired knowledge, to understand the effectiveness of an intervention, or to provide recommendations for learning. This approach can be important as we advance towards Smart Learning Environments (SLE). A literature review performed by Tabuenca et al. (2021) illustrates that the most common affordances in SLE are adaptability, traceability and the provision of feedback and recommendations.

There is a wide diversity of technologies involved in SLE, from smartphones (Heflin et al., 2017; Salcines-Talledo et al., 2022) and educational digital games (Behnamnia et al., 2023; Bile, 2022) to biometric sensors (Hernandez-de-Menendez et al., 2021); remote laboratories in blended spaces, like VISIR, are a possible source of contextual information. The need to automatically analyze the available data in Educational Data Mining and LA is essential to determine how students learn; it is then necessary to develop a culture based on data to improve teaching (Romero & Ventura, 2020) and actions' representation is a challenge to overcome in higher education institutions (Leitner et al., 2019). The collection, analysis, and visualization of logs enable instructors to discover when the learning process is taking place and provide forms of assistance using appropriate dashboards.

Learning Analytics Dashboards (LAD), or learning dashboards, are defined by Schwendimann et al. (2017) as "a single display that aggregates different indicators about learner(s), learning process(es) and/or learning context(s) into one or multiple visualizations". Their review summarized previous works and studied 55 papers on learning dashboards from 2010 to 2015 and concluded that while there was a considerable amount of research on information visualization, the effect of LADs was still mostly exploratory. Their study shows that LAD had a growing but still limited interest compared to a more general topic like learning analytics. This interest has been growing over the past few years to be a major topic in the field as reflected in the data collected from Google Trends (Fig. 1).

Learning dashboards are currently an open area of development and research. Recent reviews defined theoretical frameworks for the different goals of the LAD—from describing to making prescriptions or recommendations—(Matcha et al., 2019; Susnjak et al., 2022) and stakeholders (Park & Jo, 2015). The visualizations used and their effectiveness are also studied. Most of the LADs reviewed use data from institutional databases or VLE and are directed to help students self-regulate on their learning processes. Jivet et al. (2017) pointed that the main goal of the LADs they found consists in making learners conscient of their learning process by visualizing their own learning data, but this is not always enough to improve their competences. The authors conclude that some guidance should

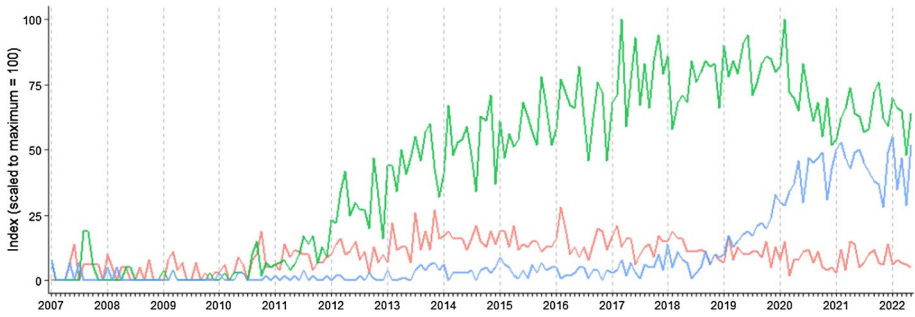

Fig. 1 Interest in Learning Analytics (green line), Educational Data Mining (red line), and Learning Dashboards (blue line) according to Google Trends (the y-axis indicates search interest relative to the highest point in the chart). This is an update of Fig. 2 in Schwendimann et al. (2017). Source: Self-authorship

be facilitated to some of these online learners that use LADs. Nevertheless, recent studies (Nguyen et al., 2021; Pozdniakov et al., 2022) reveal that researchers start trying to focus on how sensemaking takes place when using these tools. Some of the insights offered for future LADs designs include communicative prompts and question asking.

Many LADs refer to general educational applications, like Virtual Learning Environments (VLE) or e-learning tools. Other LADs have been developed to provide feedback in specific learning activities, such as in serious games (Alonso-Fernández et al., 2019; Liu et al., 2016). However, we are not aware of much work done on applying LAD to online experimental activities. Relevant exceptions are the work being done in the Lab4CE which focus on describing the general competencies of a student (Broisin et al., 2017) and the LADs implemented for following the work of the students in the inquiry learning spaces of the Next-Lab project (<https://www.golabz.eu/>) or when using the remote labs of WebLab-Deusto, now LabsLand (<https://labsland.com/>) (Orduña et al., 2014); but neither of them focus on providing support for analyzing the work done by the students on using the online activities to facilitate their learning assessment. To bridge this gap, the authors of this contribution are developing a LAD for the VISIR remote lab, VISIR-DB, using learning analytic approaches that could be extendible to other online labs. Both, VISIR and VISIR-DB, version stable-19.04 (García-Zubía et al., 2019b; Serrano et al., 2018), are presented below.

1.1 VISIR Remote Laboratory

The VISIR remote laboratory (Fig. 2) began in the late 1990s as a research project at the Blekinge Institute of Technology, Sweden (Gustavsson, 2003; Gustavsson et al., 2009). There have been many instances around the world in different universities in Sweden, Spain, Portugal, Austria, Germany, USA, Brazil, Argentina, Costa Rica, India and Australia. VISIR is mainly (but not restricted) focused on the analysis of analog electronic circuits: Ohm's law, circuits based on transistors, diodes, passive and active filters, and so on. Its design integrates complex and expensive technical equipment with a powerful interface based on HTML5 (Hernández-Jayo & García-Zubía, 2016). The VISIR client interfaces provide: (1) a breadboard or circuit connection board (circuits under test), (2) a multimeter or tester, (3) a 6-V and ± 25 -V dc power supply, (4) a function generator, and (5) a two-channel oscilloscope.

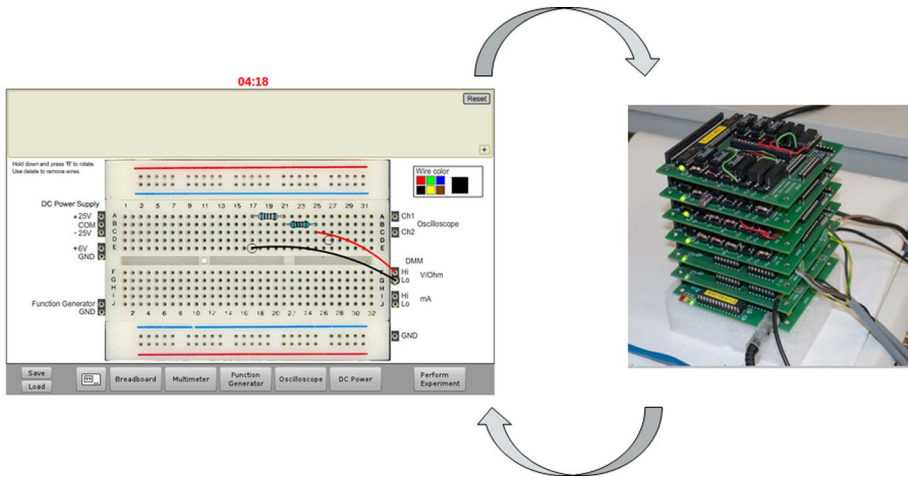

Fig. 2 Communication within VISIR remote lab, user interface (left) and physical hardware (right). Source: Self-authorship

In a typical sequence of use, students assemble their circuits on the breadboard, according to their practical exercise. They proceed following the same rules and principles as in hands-on labs: power it (using a power supply or a function generator), measure it (using the multimeter or the oscilloscope), and then analyze the obtained results. The number of circuits that a student can build over the VISIR is finite. This is because the core of this remote lab is a switching matrix where the available real components (resistors, capacitors, diodes, etc.) are connected. Before the remote lab session, the teacher has to set up the matrix, the interconnections and circuits to be taught to the students. But this process is similar in the hands-on lab, where the teacher has to provide to the students the components to be used during each lab session and to explain the circuits to be tested. It is important to highlight, following Dormido Bencomo (2002) classification of experimentation environments, that VISIR does not simulate circuits, but allows building and measuring real circuits. The VISIR management system provides multiple and concurrent access to the lab, so up to 80 students can interact in real time with a single VISIR implementation.

Other remote laboratories have been developed in analog electronics, such as NetLab (Nedic & Machotka, 2007), RemotElecLab (Fidalgo et al., 2014), and ISILab (Chirico et al., 2005). However, of these labs only NetLab, <https://netlab.unisa.edu.au/>, is still actively online, although it is not as widely used as VISIR.

1.2 VISIR-DB

VISIR-DB is a dashboard developed as a Shiny application (Chang et al., 2017) to analyze, fast and deep, the logs kept from the communication between the web interface and the real laboratory in the case of VISIR. This tool is intended for both instructors and researchers. To the instructors, the information it provides allows exploring the activity done by any specific student or group of students without having to code. Instructors only need to upload the logs generated by the interaction with VISIR on the tool, as a CSV file. To the researchers, this tool can provide ways to identify students' common errors when using

VISIR (García-Zubía et al., 2019a; Mendonça et al., 2020), like missing to connect the power source to ground, and to assess learning processes in the domain.

VISIR-DB version stable-19.04 was presented at IEEE VIS Congress in 2018 (Serrano et al., 2018), in which several meaning tables and charts were displayed to gain a better understanding on how learning of analogs circuits happens. It was initially arranged in four sections: Data Input, Global Results, Circuit-based Analysis, and User-specific Results. Each section was organized into several sections and panels. Additionally, a Help Menu was created to detail the Dashboard Structure and the meaning of the Main Terminology used. Later on, in 2019, a case study was reported at the 2019 5th Experiment International Conference (García-Zubía et al., 2019b), in which some details on the students' use of VISIR in a DC circuits experimental activity was performed and interpreted across the use of VISIR-DB.

The first section of VISIR-DB version stable-19.04, Data Input, contains a file input control to load the log file and, recently, the observation items and the assessment milestones files, both optional. Once loaded, feedback is provided in terms of number of distinct users, number of actions, and first and last logged date.

The information collected in the second section, Global Results, summarizes the results concerning time of work with the remote lab, per user (Fig. 3a), per date (Fig. 3b), or both; the total number of experiments performed, again per user, per date, or both (Fig. 3c), the experiments timeline per user including the measure type, and the distribution of unique circuits per user, so far only normalized circuits. In VISIR, an experiment is understood as a circuit and its instrumental settings as submitted to the server when clicking the button Perform experiment. Finally, the second section includes how the number of experiments (Fig. 3d), or additionally unique circuits in the new implementations, and time are related. Time represents the indefinite continued progress of the user in each of his interactions with VISIR, time events with large gaps of time have been neglected. Unique circuits are those with the same components connected in the same manner (normalized circuits).

The third section, Circuit-based Analysis, facilitates analyzing the circuits more commonly performed by the group of students. A list of common circuits, ordered by the number of times each one is created, is shown here. Each circuit can be identified in the timeline and the number of times a circuit is done by each user also appears in this section.

The fourth section, User-specific Results, shows a drop-down list of students' ID. Once a student is selected, the dashboard automatically displays a summary, the list of unique circuits created, and its history as a list of submitted experiments.

1.3 Limitations of VISIR-DB Version Stable-19.04

Despite the great potential of this version of VISIR-DB as a powerful environment for analyzing the use of VISIR and giving aggregate or individual feedback, there are two aspects where VISIR-DB needs to be improved: a better identification of unique circuits and a process-oriented assessment of students' work.

Unique (or conceptually equivalent) circuits could be interpreted as those with the same components connected in the same manner (normalized circuits); this is the approach included in VISIR-DB version stable-19.04. This algorithm allows identifying as equivalent two circuits which have the same resistors placed in different positions of the breadboard or connected using a different number of wires. However, it is common to leave unconnected components on the breadboard, for instance to reuse them later. Proceeding this way, the analysis would produce normalized circuits that are different despite the users

Fig. 3 VISIR-BD, current screenshots for some of the already available functions: **a** distribution of time of use per student. Source: Self-authorship. VISIR-BD, current screenshots for some of the already available functions: **b** time of use per date, **c** experiments performed per student and date, and **d** scatter plot of number of experiments versus time of use. Source: Self-authorship

could be intending the same measurement. Alternatively, at the World Engineering Education Forum (WEEF 2021), a simplified circuit was defined to be an improved representation so conceptually equivalent circuits will be identically expressed (Cuadros et al., 2021). Simplified circuits will then be identical when they have the same components connected in the same manner in the fragment being measured. An example is shown in Fig. 4. More details are provided in the Method section.

To improve the capacity to assess users' performance, an important aspect in the context of the SLE, as suggested by Tabuenca et al. (2021), new features should be included to VISIR-DB version stable-19.04. Among the examples of approaches that can be found in the literature to address this issue, there is the proposal of using working indicators to identify frequent errors and to evaluate the level of achievement in the use of open environments (Calvo et al., 2019; Gonçalves et al., 2018). To achieve the evaluation process, students' actions are compared to predefined steps (observation items), arranged by the instructor, and, optionally, logical combinations of them (assessment milestones).

1.4 Aims of the Paper

According to the limitations identified above, this research tries to improve the VISIR-DB capacity to assess users' performance. In this sense, we propose an approach to automatically grade the work done by the students in a remote lab, so the instructors can provide better guidance and feedback to their pupils. We present an implementation of it in the VISIR-DB (García-Zubía et al., 2019b; Serrano et al., 2018), the LAD for VISIR (Gustavsson, 2003; Gustavsson et al., 2009).

Therefore, the aims of this paper are:

- To include new analytical functionalities to improve the comparison of circuits and to assess the students' work in VISIR.
- To study the use of the VISIR remote lab along the lecturing on DC circuits.
- To assess the performance of the students in a final exam done with VISIR.

The rest of this paper is organized as follows. First, we present the methodology and context of this work. Then, we follow with the presentation of the dashboard updates and the usage analysis of VISIR along the lecturing of the topic of DC circuits in a first-year physics course and for a specific activity within it. Finally, the implications of the results are discussed and the conclusions are reported.

2 Method

This section includes the explanation of the circuit simplification process, the specifications of the work indicators files, the data collection process for both the course case study and the specific activity, and, finally, the methods used to analyze data.

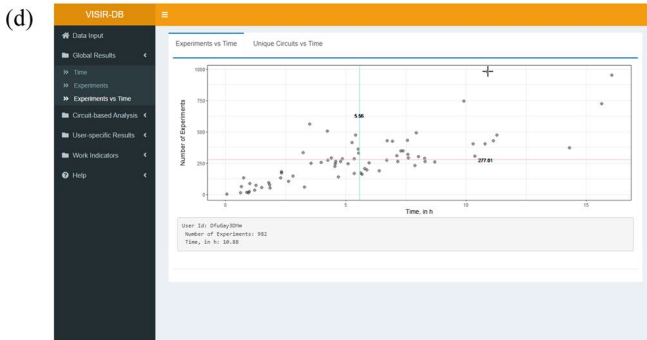
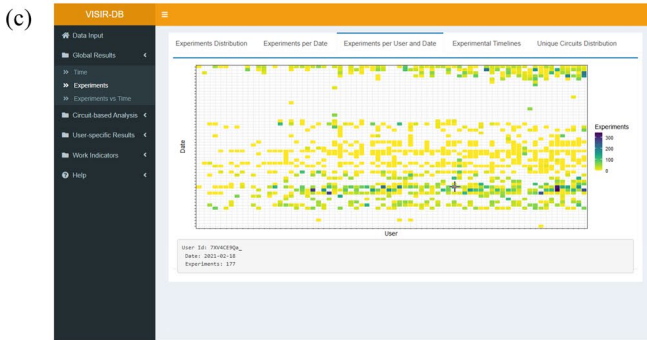
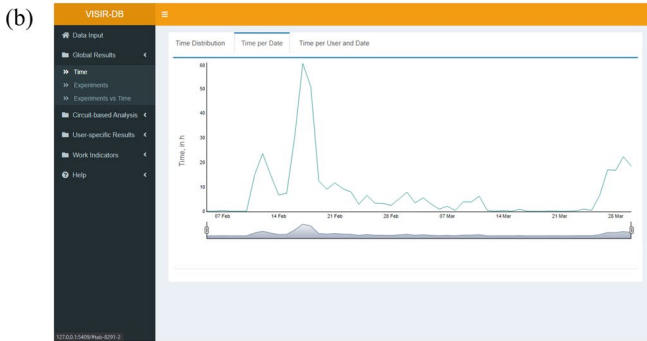
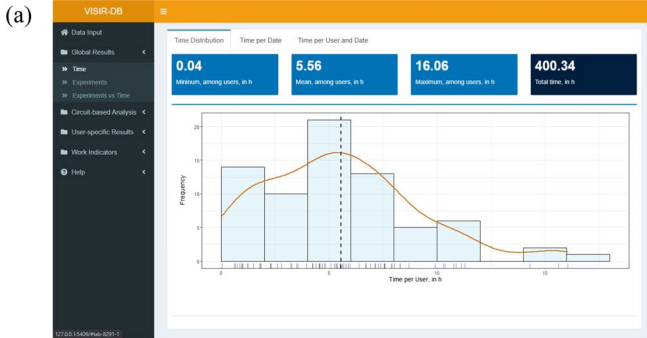

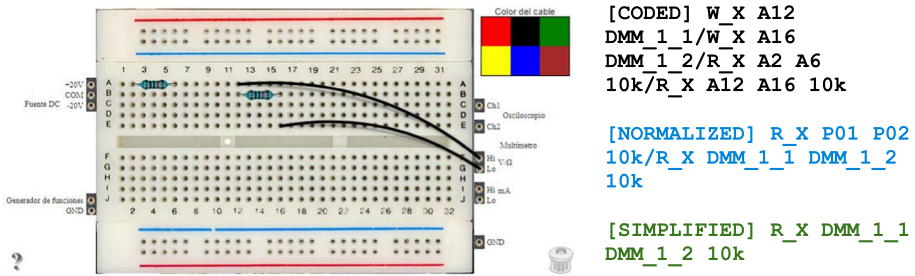

Fig. 4 Example of the process of circuit identification. On the left, circuit built in the VISIR interface; on the right, the same circuit as coded by VISIR and recodedified to normalized and simplified circuits. Source: Self-authorship

2.1 Improvement of VISIR-DB

To complement what was already available in 2019 (García-Zubía et al., 2019b), the analysis of simplified circuit, as a different way to interpret a unique circuit, and the analysis of students' performance in an activity using work indicators, have been added to VISIR-DB.

Simplified circuits were introduced by Cuadros et al. (2021). Previously only normalized circuits were available in VISIR-DB version stable-19.04. As mentioned before, a normalized circuit is a canonicalization of the circuit built by the user that is independent of the number of wires being and the position of the components. Similarly, a simplified circuit is a canonicalization of the built circuit that only considers what is connected to the multimeter and hence grasps the intended measurement of the student. Figure 5 shows the difference between the coded circuit already shown in Fig. 4, and its corresponding normalized and simplified circuit, both represented graphically.

The use of simplified circuit has been added to every place in VISIR-DB where normalized circuits were already in use. This allows an instructor to choose whether to assess all the components actually on the breadboard, using normalized circuits in this case, or to check only for the part of the circuit being measured, by selecting simplified circuits in the dashboard.

Likewise, work indicators have been introduced to the VISIR-DB. The idea of using milestones to assess students work was introduced by Calvo et al. (2019) for a traced version of *R Commander*. According to this work, students work can be assessed by comparing each action to a predefined set of observation items. A formal assessment can be constructed with a set of assessments milestones, which are logical combinations of the check results for the observation items. Now this has been adapted for its inclusion in VISIR-DB.

In the case of VISIR-DB, observation items are not checked against the full action trace but against a rootless XML string that includes (1) the coded circuit, (2) the normalized circuit, (3) the simplified circuit, (4) the result of the multimeter, (5) the voltage of the source, and (6) the magnitude the multimeter is set to measure. An example of a string against which work indicators will be assessed is.

<p>Built circuit</p>		<pre>W_X A12 DMM_1_1/W_X A16 DMM_1_2/R_X A2 A6 10k/R_X A12 A16 10k</pre>
<p>Normalized circuit</p>		<pre>R_X P01 P02 10k/R_X DMM_1_1 DMM_1_2 10k</pre>
<p>Simplified circuit</p>		<pre>R_X DMM_1_1 DMM_1_2 10k</pre>

Fig. 5 Comparison of coded, normalized and simplified circuits. Source: Self-authorship

```
<circuit>W_X A15 A17/W_X A9 A11/W_X VDC+25V_1_1 A9/W_X
A21 0/W_X 0 VDCCOM_1_1/W_X A17 DMM_1_1/W_X A21
DMM_1_2/R_X A9 A13 1k/R_X A13 A17 10k/R_X A17 A21 1k/R_X
A11 A15 10k</circuit>
<normalizedCircuit>R_X P01 DMM_1_1 10k/R_X P01
VDC+25V_1_1 1k/R_X DMM_1_1 GND 1k/R_X DMM_1_1 VDC+25V_1_1
10k/W_X DMM_1_2 GND/W_X GND
VDCCOM_1_1</normalizedCircuit>
<simplifiedCircuit>R_X P01 DMM_1_1 10k/R_X P01
VDC+25V_1_1 1k/R_X DMM_1_1 GND 1k/R_X DMM_1_1 VDC+25V_1_1
10k/W_X DMM_1_2 GND/W_X GND
VDCCOM_1_1</simplifiedCircuit>
<result>1.589682</result>
<voltage>9.999547</voltage>
<measure>dc vo</measure>
```

Observation items are specified in a tab-separated unquoted text file, which must be prepared outside of VISIR-DB. The file includes three columns, (1) a unique name for the observation item (obsItems), (2) a regular expression which will be matched to each experiment (regExps), and (3) a piece of calculation in R that evaluates to either TRUE or FALSE (if a calculation is not required, TRUE should be added to this column, logTests). A first line with the headers is expected and the file can contain as many observation items as required by the desired analysis. A simple observation item that checks if there is any experiment measuring DC voltage follows.

obsItems	regExps	logTests
OI	<measure>dc vo</measure>	TRUE

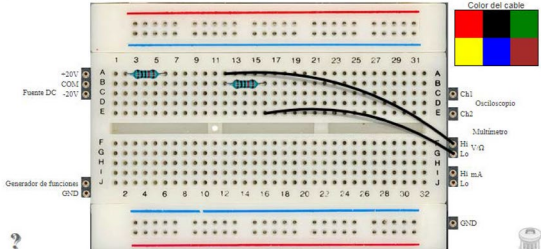
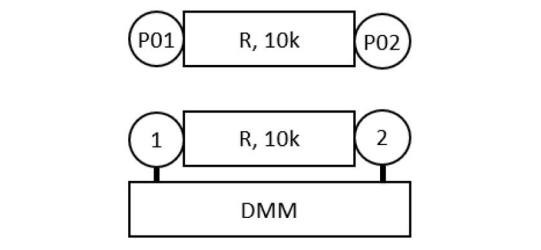
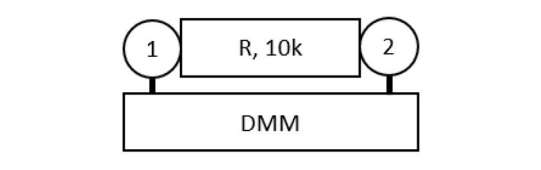
Given the observation items, a second assessment level can be implemented through assessment milestones. While observation items can be used to detect any aspect of students' work that can be of interest for their evaluation or feedback, assessment milestones can be thought as elements in a rubric. Each assessment milestone corresponds to a fraction of the grade, but any of them might be achievable through different circuits or, in the contrary, require more than a single experiment to be considered as done. In any case, assessment milestones are optional. If omitted, each observation item is also interpreted as its own assessment milestone. Assessment milestones are also encoded in a tab-separated unquoted text file. Each milestone includes two columns, (1) a unique name and (2) a logical evaluation which refers to the observation items.

The improved version of the dashboard (stable-21.12) includes two file selection controls to load the observation items and the assessment milestones files. New visualizations are also added in a new Work Indicators section. These allow the instructor to quickly check the percentage of students that reached each work indicator and also whether any student achieved any of them.

2.2 Data Collection

To achieve the second and the third goal of the present project, those are to study the use of the VISIR remote lab along the lecturing on DC circuits and to assess the performance of the students in a final exam done with VISIR, two sets of logs should be collected. For the first one, users belonging to a one-semester course of Electronics at the University of Deusto, from February 1 2021 to March 30 2021, have been taken into consideration. This course was taught in two groups (58 students in the largest group, who studied in Spanish, and 16 students in the second group who took the subject in English); a total of 74 students were enrolled. The subject is common to the first year of all the industrial branch degrees: Industrial Technologies Engineering, Electronics and Automation Engineering, Industrial Organization Engineering, and Mechanical Engineering. This subject requires assembly and measurement of analog and digital electronics basic circuits, including corresponding instrumentation. It consists of three theoretical hours and one practical hour per week, which is oriented to an intensive use of both hands-on and remote laboratories. During the face-to-face practical sessions of February 11 and 16 (2021), related to analog electronics, VISIR was used intensely. The VISIR remote lab was also used as a complement to the

practical classes, since students could use VISIR from home to complete their unfinished exercises from the lab sessions.

VISIR was also used during the evaluation of the subject (March 30, 2021), where students had to demonstrate how in addition to reporting the mathematical models that describe the behavior of a circuit, they were able to assemble, measure and characterize that circuit using VISIR. To analyze the exam activity, a second set of logs, generated from the users of the largest group on March 30 from 16.00 and 18.30 CET, is explored. In both cases, experiments including AC components have been excluded.

2.3 Data Analysis Tools

This section includes the description of the process to generate the work indicators to deeply assess students' performance in the final exam and how the new version of VISIR-DB (stable-21.12) helps better analyse the use of VISIR for both, during the course and during the exam.

To integrate the simplification process in the dashboard, a checkbox has been added to the interface (Circuit-based Analysis and User-specific Results sections). This checkbox is unselected by default, which means that normalized circuits are analysed. When selected, simplified circuits are used instead. Using this new level of canonicalization of a built circuit, additional errors can be detected, improving the understanding of errors, and it can be easy to see what students are trying to measure. The previous visualizations, corresponding to time, experiments and circuits, make the dashboard a useful tool for monitoring relevant information related to the course.

Work indicators should be established in collaboration to the instructor to reproduce the expected steps to correctly solve the exam or to identify potential errors.

The exam question referring to VISIR consists in determining some physical magnitudes (one equivalent resistance, three currents and five voltages) of the circuit shown in Fig. 6.

Annex B in the supplemental information includes the list of 14 observation items and 9 assessment milestones generated to assess the students' performance. Looking at the second observation item in Annex B, it can be seen that it is named OT1_RT (first column), it looks for a measurement of resistance (column 2), where the value obtained in the measurement is between 6.20 k Ω and 6.25 k Ω (column 3). This range accounts for the tolerance in the value of the resistors, permutations of their positions, and the error introduced by the

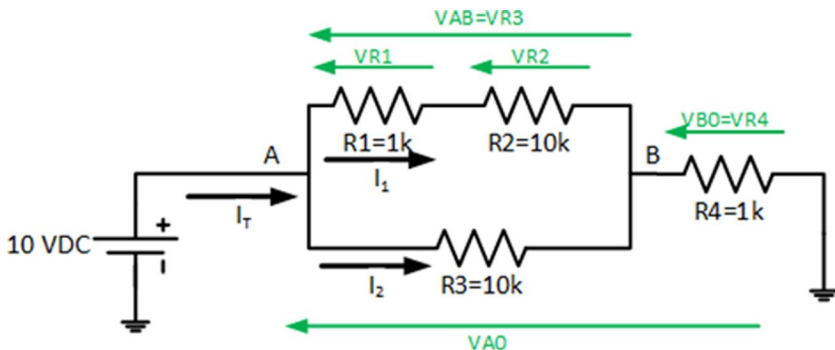

Fig. 6 Circuit to be measured in the exam on March 30. Source: Self-authorship

instruments. For a specific user of the remote lab, every experiment will be matched to this query.

```
OT1_RT <result>(.*</result>.*<measure>resis</measure>
as.numeric(m[[1]])>=6200&as.numeric(m[[1]])<=6250
```

The user will be considered to reach this observation item if at least one experiment is found to match it. Observation items may refer to expected steps in the resolution process of an activity, elements of a grading template in an exam, errors or mistakes that could arise, or any other aspect that could be of interest to the faculty or a research team.

Assessment milestones are also encoded in a tab-separated unquoted text file. Each milestone includes a name with a logical evaluation which refers to the observation items. For example, the first assessment milestone in Annex B is named E1_RT (column 1, assMils) and it is reached when the student reaches both observation item 001_4R and OT1_RT (column 2, logEvals).

assMils	logEvals
E1_RT	om['001_4R']&om['OT1_RT']

Again, the user will be considered to reach this assessment milestone if at least 001_4R and OT1_RT are achieved.

Two different visualizations are used to easily analyze the accomplishment of both work indicators, bar charts to identify the percentage of students who achieved each indicator and heatmaps to detect whether every student achieved or not each indicator. Differentiated behaviors can be observed among students from the resolution of the assessment activity.

3 Results

In this section, the new features implemented in VISIR-DB to improve the comparison of circuits and to assess the students' work are presented and showcased using a course-long study and a particular assessment activity. First, we discuss the additional characteristics of VISIR-DB. Next, we use VISIR-DB to analyze the logs recorded along the lecturing on DC circuits. And, finally, VISIR-DB is used to assess the performance of the students in a final exam done with VISIR.

3.1 Improved VISIR-DB

VISIR-DB version stable-21.12 has a new section called Work Indicators, which helps the instructors understand the relationship between the students work and the instructor's expectations for a specific task. Data Input section has also been modified to allow VISIR-DB users uploading predetermined working indicators (see Fig. 7). Each place where unique circuits are included has been changed to consider both normalized and simplified circuits. Previously, only normalized circuits were considered.

Check to use simplified circuits (normalized circuits when unchecked)

Common Circuits Circuit in Timeline Circuit per User

Show entries Search:

	Simplified Circuits	Times Tested
1		2395
2	R_X P01 DMM_1_1 10k/R_X P01 DMM_1_1 1k/R_X P01 DMM_1_2 10k/R_X P01 DMM_1_2 1k	448
3	R_X DMM_1_1 DMM_1_2 1k	312
4	R_X P01 GND 1k/R_X P01 VDC+25V_1_1 1k/R_X GND VDC+25V_1_1 10k/R_X GND VDC+25V_1_1 10k/W_X DMM_1_1 VDC+25V_1_1/W_X DMM_1_2 GND/W_X GND VDCCOM_1_1	241
5	R_X P01 DMM_1_1 1k/R_X P01 DMM_1_2 1k	234
6	R_X DMM_1_1 DMM_1_2 1k/R_X DMM_1_1 DMM_1_2 1k	221
7	R_X DMM_1_1 DMM_1_2 10k	217
8	R_X DMM_1_1 GND 100/R_X DMM_1_1 VDC+25V_1_1 1k/W_X DMM_1_2 GND/W_X GND VDCCOM_1_1	194
9	R_X P01 GND 10k/R_X P01 IPROBE_1_2 1k/W_X GND VDCCOM_1_1/W_X IPROBE_1_1 VDC+25V_1_1	166
10	R_X P01 GND 1k/R_X P01 IPROBE_1_2 1k/R_X GND IPROBE_1_2 10k/R_X GND IPROBE_1_2 10k/W_X GND VDCCOM_1_1/W_X IPROBE_1_1 VDC+25V_1_1	164

Showing 1 to 10 of 2,790 entries Previous 2 3 4 5 ... 279 Next

Fig. 9 VISIR-BD table of the most common unique circuits (as simplified circuits). Source: Self-authorship

Each type of analysis offers different insights on the students' work. For instance, an empty normalized circuit (row 7, Fig. 8) means that neither component nor meaningful wires were part of the circuit assembled by the user. However, an empty simplified circuit (row 1, Fig. 9) means the lack of a correct measurement in any fragment of the circuit; this happens when the multimeter is missing or not properly connected by both poles.

The use of work indicators requires loading up to two text files in the Data Input panel, as described in the Method section. Once loaded, last section in VISIR-DB displays the users' performance, indicating the proportion of users that achieved each work indicator (observation items or assessment milestones), and the achievements per user.

Work indicators are visualized in the corresponding section of VISIR-DB both as the group performance, percentage of students reaching each indicator (Fig. 10), and as individual performances, in a heatmap showing which indicators are attained by each student (Fig. 11). The results shown in these charts are further discussed when analyzing the use case.

VISIR-DB version stable-21.12 keeps processed data available in the R environment once the dashboard is closed. The available data frames can then be reused for further analyses or can be exported to other file formats.

For additional details on the comparison of both versions of VISIR-DB, stable-19.04 and stable-21.12, see Annex A in the supplemental information.

3.2 Course-long Analysis

The log file includes information about 27,704 actions of 72 users, out of 74 enrolled students (Fig. 12). The average number of time (in hours) working actively with VISIR per student amounts to 5.56 and there is a bias to the right, being the maximum number of

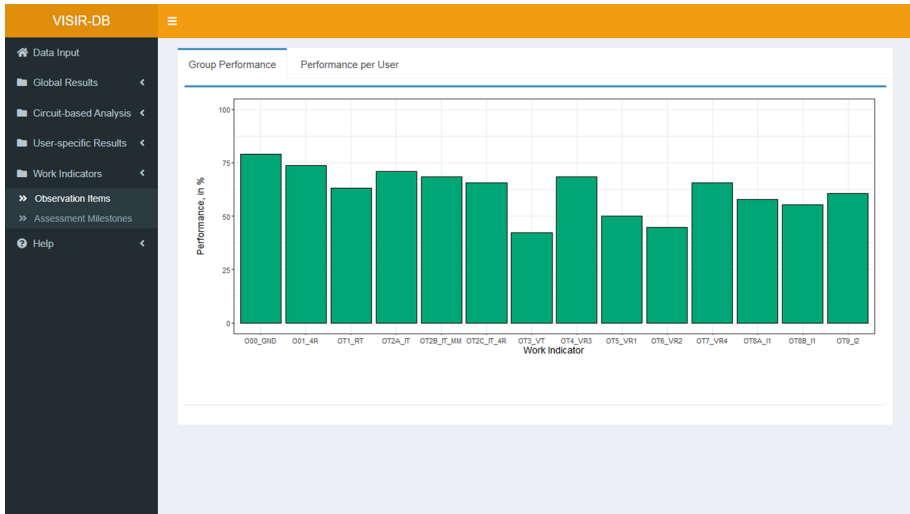

Fig. 10 VISIR-BD group performance per observation item. Source: Self-authorship

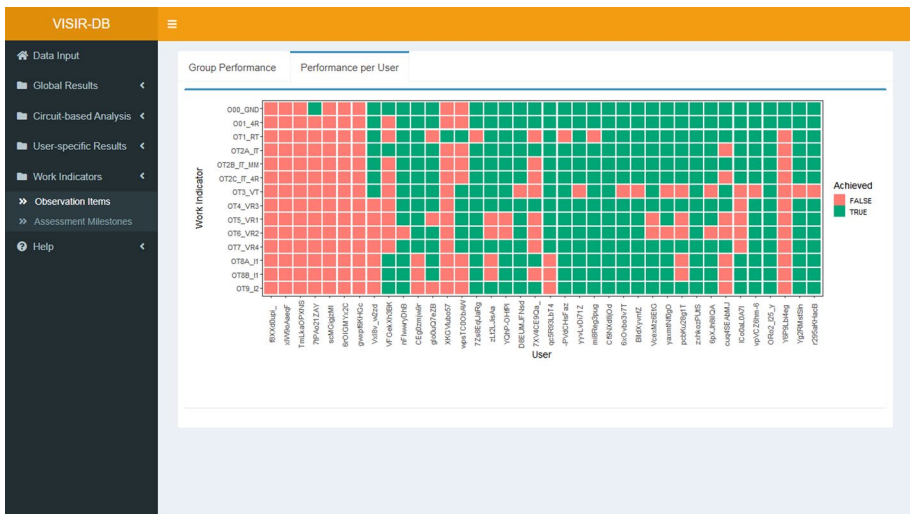

Fig. 11 VISIR-BD individual performance per observation items and student. Source: Self-authorship

hours per student equal to 16.06 (Fig. 13). However, there is also a group of students that do not seem to be engaged by VISIR (or by the subject itself), as they used it for less than two hours along the entire course.

The total time distribution per date (Fig. 14) shows some peaks that clearly correspond to the practical sessions mentioned above (February 11 and 16, 2021) and the final exam (March 30, 2021). The first practical session was basically conducted by the instructor and, then, students worked in pairs with VISIR. On the second practical session, the students

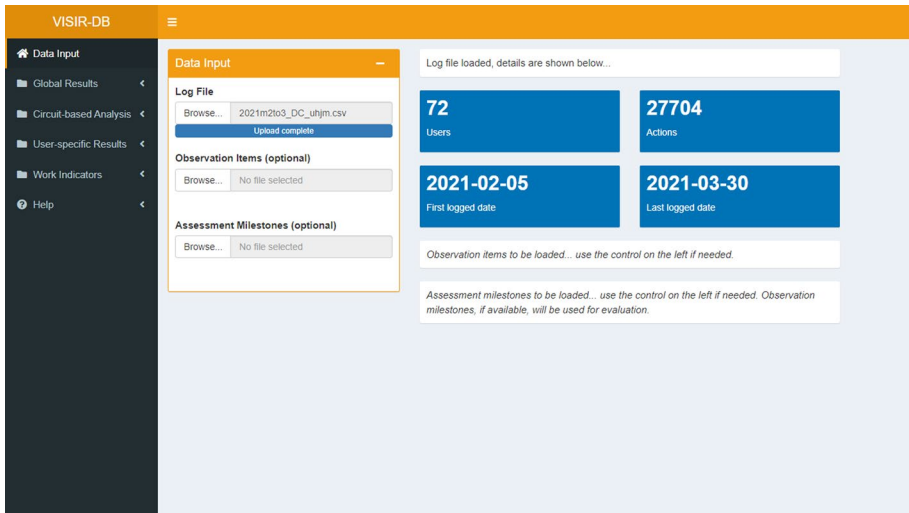

Fig. 12 VISIR-DB front page. Source: Self-authorship

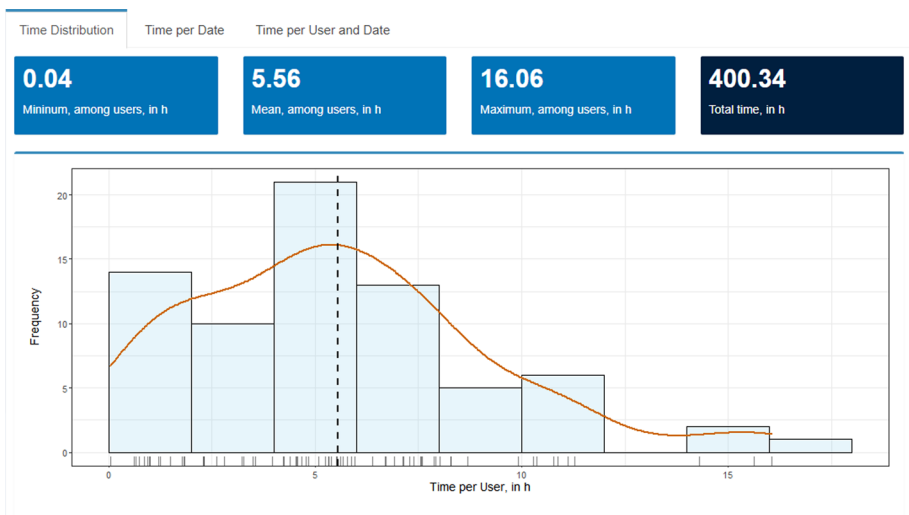

Fig. 13 VISIR-DB time distribution. Source: Self-authorship

worked individually and this is why the total time of use on that date (about 60 h) is larger than on the first one. Afterwards, for the final exam, students also worked individually but the problem they had to solve was shorter and required less dedication. A substantial amount of work can be observed too during the study for the final exam. Although VISIR is freely available to the students at any time, it seems to be used essentially to solve the tasks assigned by the instructors. It is rarely used by students in their autonomous learning.

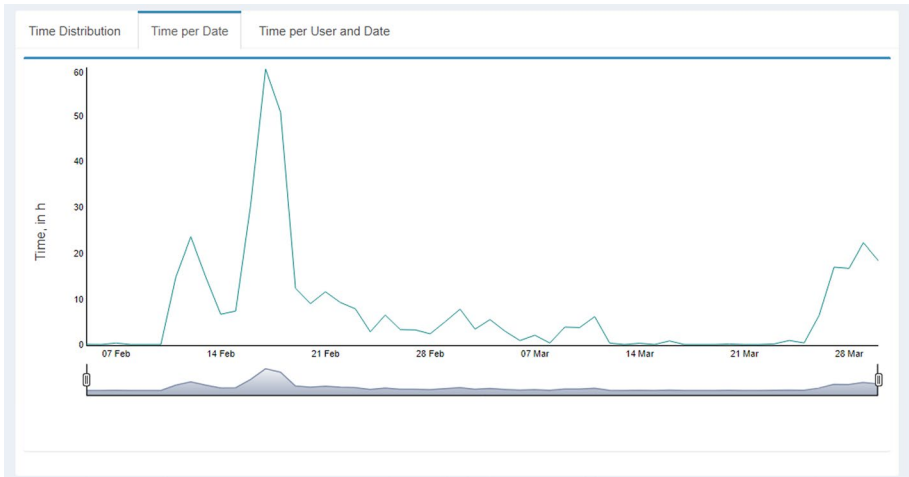

Fig. 14 VISIR-DB time distribution per date. Source: Self-authorship

Another meaningful visualization consists in identifying the total time of work per user and date (Fig. 15), in which a clear overview of individual performance can be perceived. For instance, the interaction with VISIR certainly increases some days before the final exam date (shown with a red arrow). Placing the mouse over a data point, user, date, and time dedicated can be seen below the visualization. Similar information can be obtained when checking the number of experiments performed and the unique circuits obtained instead of the time dedicated.

When visualizing the number of experiments or the number of unique circuits vs total time, important information can be extracted too. Figure 16 shows the relationship between the number of experiments and time dedication. Each student is represented with a marker. Some low performance students are identified, all of them located in the lower left corner

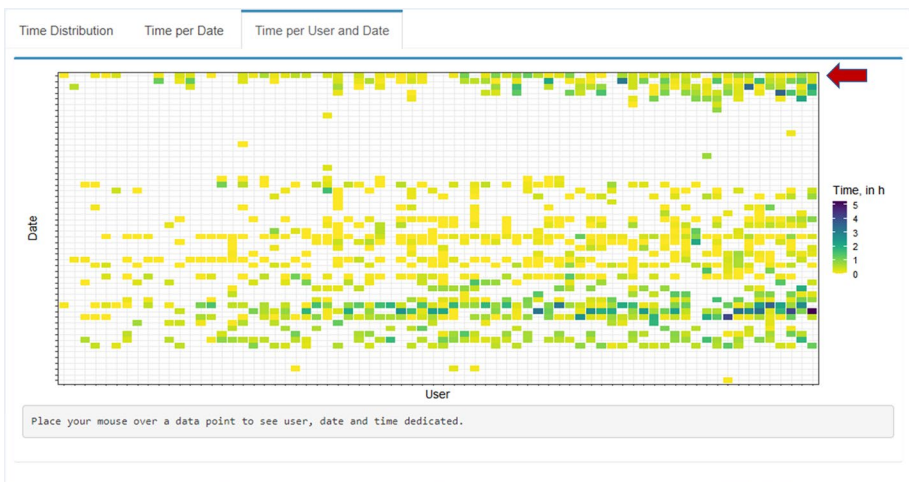

Fig. 15 VISIR-DB time distribution per user and date. Source: Self-authorship

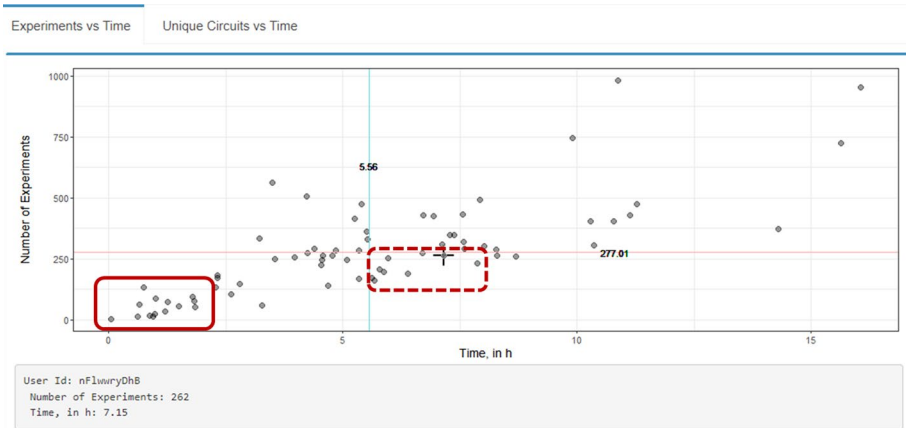

Fig. 16 VISIR-DB number of experiments vs time. Source: Self-authorship

of the chart (encircled with solid red line), but other kinds of students’ performance can be highlighted, for instance, those with large time dedication but with low number of experiments performed (dashed red line). Again, hovering, more detailed information can be observed; the student pointed by the cursor in Fig. 16 is nFlwryDhB.

Beyond the analyses based on time, VISIR-DB helps understand what experiments the students are undertaking. The common circuits section (Fig. 17) summarizes the unique circuits (normalized or simplified) corresponding to the experiments performed by the users, ordered by decreasing frequency. Given this information, teachers can revise if the expected circuits are properly built. Frequent errors could also be detected here, for

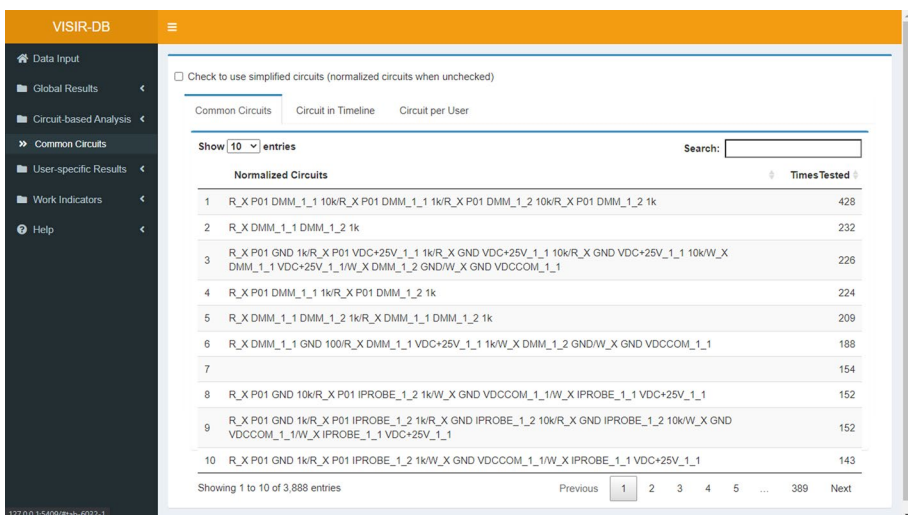

Fig. 17 Common circuits

instance circuits without multimeter. In particular, Fig. 17 shows that 154 experiments have been performed without any multimeter or electrical components in the breadboard. These circuits appear as a blank string after the normalization process.

In the current version of VISIR-DB (stable-21.12), thanks to the option to compute the simplified circuits, instructors can focus on the part of the circuit that is being measured which should be closer to the students' intention.

The next VISIR-DB section, User-specific Results, is intended to help instructors provide specific feedback to individual students. For instance, a summary of nFlwryDhB student performance is obtained (Fig. 18a). He or she spent 7.15 h learning with the remote lab and performed 262 experiments. This is right below the mean number of experiments in a longer time than the mean of the entire group. These 262 experiments correspond to 132 unique (as normalized) circuits. 55 of the experiments were measurement errors.

Furthermore, the list of unique circuits (Fig. 18b) and the history of experiments of the student selected (Fig. 18c) can also be explored. In Fig. 18b, we learn that nFlwryDhB misconnected the multimeter in 42 of the 262 experiments he/she performed. In Fig. 18c, the instructor can look at the specific circuits constructed by nFlwryDhB; the repetition of the measurements can be easily detected and, with some training, one can read that the student successfully calculated first the equivalent resistor of two 1 k resistors connected in serial, to follow with their combination in parallel.

As exemplified above, this tool should allow instructors to provide faster, better and personalized feedback to students about their learning process in this topic. Faster, as it automatically provides quick insights into students' work without having to worry about analyzing the log files manually. Better, as the diverse visualizations allow deeper analyses of what the students did when solving the activity or all along the course. Personalized, as it can be used to easily explore what an individual did and to compare its work to the group.

3.3 Assisted Assessment of a VISIR Activity

The second analysis corresponds to the use VISIR-DB with the data collected in an exam of the big group (58 students enrolled). 38 students attempted to solve the VISIR problem in this exam and their work totals 889 actions (Fig. 19). As mentioned in the Method section, work indicators (14 observations items and 9 assessment milestones) have been loaded in the interface too.

Many relevant insights can be obtained when interacting with the students' traces with VISIR-DB. For instance, looking at the scatterplot of the number of simplified circuits versus time (Fig. 20), it is easy to identify a number of students (encircled in red) who made a very limited use of VISIR during the exam and consequently they made no more than five unique circuits. Nevertheless, there are other students (encircled in green) who assemble more than ten unique circuits in less than 15 min. At the very least, nine unique circuits were required to take all the measurements requested in the exam.

A deeper look into the students' work when solving the exam is shown in Fig. 21 where students are ordered by the amount of time spent with VISIR during the exam. Some students are able to assemble correct circuits (green arrows) while others make errors almost every time they perform an experiment (red arrows). Framed in green, the nFlwryDhB student reached to effectively build and measure the proposed circuit without any error.

An inspection to the unique circuits (Fig. 22, as simplified circuits) shows there are 140 errors, as empty simplified circuits. The measurement of the total current (IT in Fig. 6) is tested 44 times.

(a)

Select a user...
nFlwryDhB

Summary | List of Unique Circuits | History of Experiments

379 Actions	7.15 Total Time, in h	262 Experiments
132 Normalized Circuits	117 Simplified Circuits	79 Resistance Measurements
90 Current Measurements	38 Voltage Measurements	55 Errors in measurement

(b)

Select a user...
nFlwryDhB

Summary | List of Unique Circuits | History of Experiments

Check to use simplified circuits (normalized circuits when unchecked)

Show **10** entries Search:

Simplified Circuit	Times Tested
1	42
2 R_X P01 GND 10k/R_X P01 GND 10k/R_X P01 IPROBE_1_2 1k/W_X GND VDCCOM_1_1/W_X IPROBE_1_1 VDC+25V_1_1	9
3 R_X GND IPROBE_1_2 100/W_X GND VDCCOM_1_1/W_X IPROBE_1_1 VDC+25V_1_1	7
4 R_X P01 GND 10k/R_X P01 IPROBE_1_2 1k/W_X GND VDCCOM_1_1/W_X IPROBE_1_1 VDC+25V_1_1	7
5 R_X P01 DMM_1_1 1k/R_X P01 DMM_1_2 1k/R_X DMM_1_1 DMM_1_2 100/R_X DMM_1_1 DMM_1_2 10k	5
6 R_X P01 DMM_1_1 1k/R_X P02 DMM_1_2 10k/R_X P02 DMM_1_2 10k	5
7 R_X P01 P02 1k/R_X P02 IPROBE_1_2 10k/R_X P02 IPROBE_1_2 10k/R_X P01 IPROBE_1_2 1k/W_X IPROBE_1_1 VDC+25V_1_1	5
8 R_X GND IPROBE_1_1 10k/R_X GND IPROBE_1_1 10k/R_X IPROBE_1_2 VDC+25V_1_1 1k/W_X GND VDCCOM_1_1	4
9 R_X P01 DMM_1_1 10k/R_X P01 DMM_1_1 1k/R_X P01 DMM_1_2 10k/R_X P01 DMM_1_2 1k	4

(c)

Select a user...
nFlwryDhB

Summary | List of Unique Circuits | History of Experiments

Show **10** entries Search:

	Time	Sent Date	Coded Circuit	Measure
11471	7.95	2021-02-12 08:38:19	W_X DMM_1_1 A13/W_X DMM_1_2 A17/R_X A13 A17 1k	Resistance
11472	13.12	2021-02-12 08:43:29	W_X DMM_1_1 A12/W_X DMM_1_2 A20/R_X A12 A16 1k/R_X A16 A20 1k	Resistance
11473	13.47	2021-02-12 08:43:50	W_X DMM_1_1 A12/W_X DMM_1_2 A20/R_X A12 A16 1k/R_X A16 A20 1k	Resistance
11474	14.08	2021-02-12 08:44:27	W_X DMM_1_1 A12/W_X DMM_1_2 A16/R_X A12 A16 1k/R_X A16 A20 1k	Resistance
11475	14.97	2021-02-12 08:45:20	W_X DMM_1_1 A15/W_X DMM_1_2 A20/R_X A15 A19 1k/R_X A15 A19 1k	Resistance
11476	15.02	2021-02-12 08:45:23	W_X DMM_1_1 A15/W_X DMM_1_2 A20/R_X A15 A19 1k/R_X A15 A19 1k	Resistance
11477	15.22	2021-02-12 08:45:35	W_X DMM_1_1 A15/W_X DMM_1_2 A19/R_X A15 A19 1k/R_X A15 A19 1k	Resistance
11478	15.25	2021-02-12 08:45:37	W_X DMM_1_1 A15/W_X DMM_1_2 A19/R_X A15 A19 1k/R_X A15 A19 1k	Resistance
11479	15.48	2021-02-12 08:45:51	W_X DMM_1_1 A15/W_X DMM_1_2 A19/R_X A15 A19 1k/R_X F15 F19 1k	Resistance
11480	18.08	2021-02-12 08:48:27	W_X F15 F17/W_X A15 A17/W_X DMM_1_1 A17/R_X A15 F15 1k/R_X A17 F17 1k	Resistance

Showing 1 to 10 of 262 entries Previous **1** 2 3 4 5 ... 27 Next

Fig. 18 VISIR-DB user-specific results. **a** summary of the student selected, **b** list of unique circuits obtained by this student, and **c** its history of experiments performed. Source: Self-authorship

Fig. 19 VISIR-DB summary of the exam data and of the work indicators. Source: Self-authorship

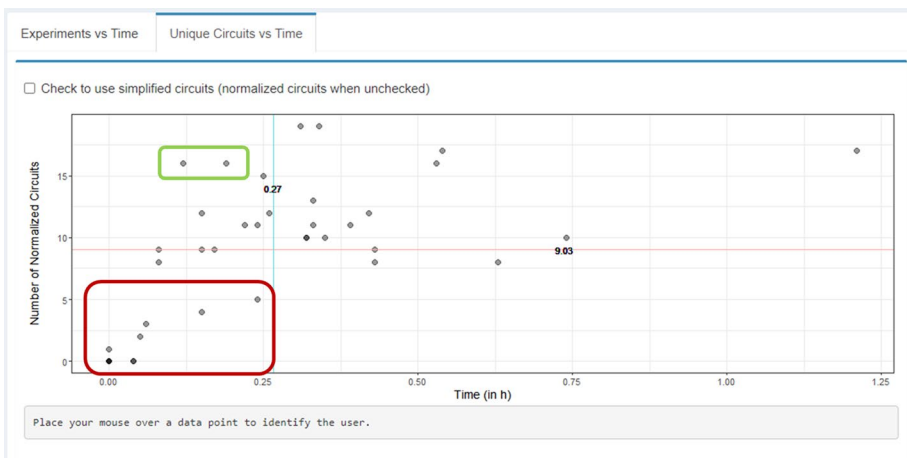
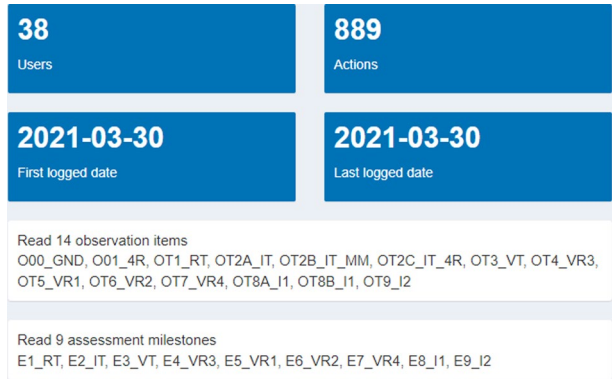

Fig. 20 VISIR-DB scatterplot of the number of normalized circuits versus time. Source: Self-authorship

Visualizations in Fig. 23a and b permit to inspect when and how many times each student actually assembled this circuit to measure the total current and performed experiments with it.

Work indicators, which have been presented above and are available in the SI (Annex B), include items to check if each student built a four-resistors circuit and if all the required measurements were taken. In VISIR-DB, the visualizations supported by the work indicators (Fig. 24), allow to check which of these assessment elements were harder and which students reached each of them. There are six students (red vertical lines) that did not reach any of the observation items and eleven students which did not reach any of the assessment milestones, Fig. 24(b and d) respectively. Students are presented in the same order than in Fig. 21.

Besides the information that can be obtained for the entire class, specific analyses can be extracted at the level of an individual student. For instance, despite the nFlw-wryDhB student was initially included in the group of students who had a large time of dedication but performed less experiments than the median, he/she accomplished all

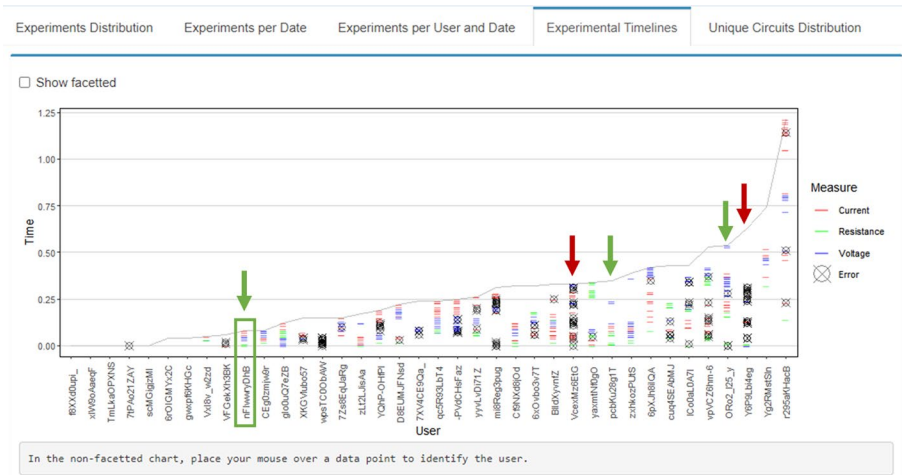

Fig. 21 VISIR-DB timelines of the students during the exam. Source: Self-authorship

Check to use simplified circuits (normalized circuits when unchecked)

Common Circuits Circuit in Timeline Circuit per User

Show 10 entries Search:

Simplified Circuits	Times Tested
1	140
2 R_X P01 P02 10k/R_X P02 GND 1k/R_X P02 IPROBE_1_2 10k/R_X P01 IPROBE_1_2 1k/W_X GND VDCCOM_1_1/W_X IPROBE_1_1 VDC+25V_1_1	44
3 R_X P01 DMM_1_2 10k/R_X P01 VDC+25V_1_1 1k/R_X DMM_1_2 GND 1k/R_X DMM_1_2 VDC+25V_1_1 10k/W_X DMM_1_1 VDC+25V_1_1/W_X GND VDCCOM_1_1	40
4 R_X P01 DMM_1_1 10k/R_X P01 VDC+25V_1_1 1k/R_X DMM_1_1 GND 1k/R_X DMM_1_1 VDC+25V_1_1 10k/W_X DMM_1_2 GND/W_X GND VDCCOM_1_1	35
5 R_X P01 P02 10k/R_X P02 GND 1k/R_X P02 IPROBE_1_2 10k/R_X P01 VDC+25V_1_1 1k/W_X GND VDCCOM_1_1/W_X IPROBE_1_1 VDC+25V_1_1	30
6 R_X DMM_1_1 DMM_1_2 10k/R_X DMM_1_1 VDC+25V_1_1 1k/R_X DMM_1_2 GND 1k/R_X DMM_1_2 VDC+25V_1_1 10k/W_X GND VDCCOM_1_1	27
7 R_X P01 P02 10k/R_X P02 GND 1k/R_X P01 IPROBE_1_2 1k/R_X P02 VDC+25V_1_1 10k/W_X GND VDCCOM_1_1/W_X IPROBE_1_1 VDC+25V_1_1	24
8 R_X P01 P02 10k/R_X P02 GND 1k/R_X P02 VDC+25V_1_1 10k/R_X P01 VDC+25V_1_1 1k/W_X DMM_1_1 VDC+25V_1_1/W_X DMM_1_2 GND/W_X GND VDCCOM_1_1	24
9 R_X P01 DMM_1_1 1k/R_X P01 DMM_1_2 10k/R_X DMM_1_1 DMM_1_2 10k/R_X DMM_1_2 GND 1k/W_X DMM_1_1 VDC+25V_1_1/W_X GND VDCCOM_1_1	23

Fig. 22 VISIR-DB table of the most common simplified circuits during the exam. Source: Self-authorship

but one of the observation items and the assessment milestones of the exam. This student is also highlighted in Fig. 24b and d. He/she failed to measure the voltage drop in the resistor R2 (see the exam statement in Fig. 6), thus the observation item OT6_VR2 is not achieved. Consequently, he/she also missed the assessment milestone E6_VR2 which requires this observation item.

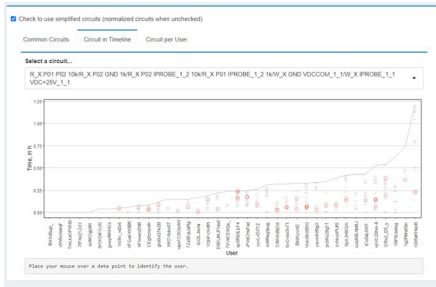

(a)

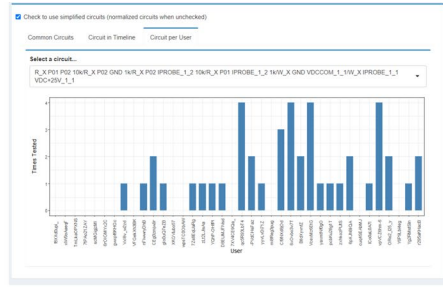

(b)

Fig. 23 VISIR-DB visualization for **a** time when each user makes a circuit, and **b** the number of experiments done for a circuit per student. Source: Self-authorship

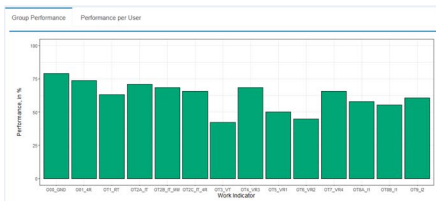

(a)

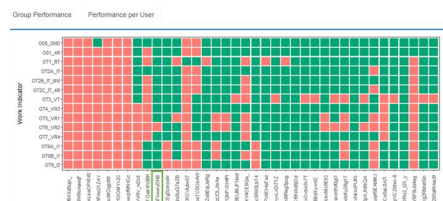

(b)

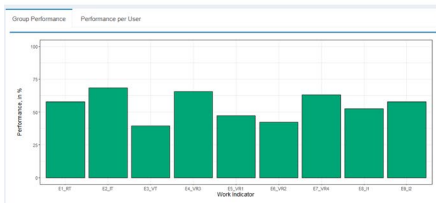

(c)

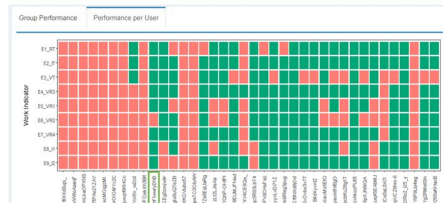

(d)

Fig. 24 VISIR-DB group **a** and **c** and individual **b** and **d** performances for the exam: observation items in the first row and assessment milestones in the second row. Source: Self-authorship

4 Discussion and Conclusions

VISIR-DB is a tool which aims to monitor and understand VISIR users' learning process. Simplified circuits and work indicators have been included in VISIR-DB version stable-21.12. This current version includes additional visualizations and analyses that make it more functional, facilitating the assessment of students' work, the identification of at-risk students, and the provision of better feedback. The use of the simplified circuits as a way to identify equivalent circuits provides a higher-level indicator to understand whether a user assembled a required circuit or not. The use of work indicators provides an adaptable way for instructors to analyze the performance on a specific activity. Therefore, the current

version of the LAD should help the instructors give feedback, assessment and recommendations to the students, in relation to the task expected resolution.

Data collected and analyzed for the entire topic in a group of 74 students have been explored with VISIR-DB. Results allow the identification of the students who didn't use the remote laboratory or had significant issues in working with it, spending a limited amount of time working with this learning environment. In general, students mainly use VISIR when directed to do so. They rarely use the remote lab when studying on their own, although VISIR is available 24/7. Regarding to the time of use and the number of experiments performed, variability is large among the group of students. The range of usage time is larger than 16 h per user. The dashboard also allows detecting common circuits and errors, and focusing on any specific student to provide individualized feedback.

Similarly, a specific learning activity can be explored with VISIR-DB. By using observation items and assessment milestones, the analysis of group and students' performance can be adapted to any activity or instructor need. Students' work on a specific exam question has been examined. In this case, an assessment model mimicking the standard correction of the exam question is in-place to check whether each student measured each of the electric magnitudes asked in the problem. This analysis clearly shows which users never built the required circuit and what measurements have been harder for these students. Additionally, we can take apart students that don't make any error during the exam from others that still have problems taking electrical measurements. This is independent of the number of experiments performed in the assessment activity. Around 29% of the students did not achieved any of the assessment milestones stated for this activity; these students can be easily detected using VISIR-DB. Specific interventions can then be decided based on these observations.

The new implementations in VISIR-DB make the dashboard more flexible and adaptable to instructors' needs: (1) providing feedback on students' learning activities and performance, (2) identifying and treating at-risk students, and (3) exploring students' individual performance. This is aligned with the goals identified by Park and Jo (2015) in their review of LADs.

Despite VISIR-DB offers several visualizations and analyses of the students' work, there are some limitations and some desirable features that are still work in progress. These are presented here to give a more realistic picture of our current LAD for VISIR, and our roadmap for the next few years.

First, the analysis of the VISIR traces presented here is not readily available for any implementation of VISIR. While any remote laboratory requires sending messages from the client to the remote lab server, these messages are not often recorded so they can not always be analyzed. Whether the messages are collected or not, depends on the remote lab managing system (RLMS) being used and its configuration. In the VISIR implementation used in this research, the WebLab-Deusto RLMS (Orduña et al., 2018) is being used and the traces of the users' actions are recorded.

Second, the process of collecting the traces and filtering them to select dates, users and circuit types (i.e. DC or AC) is not automated, and data have to be manually pulled from the database. Filtering is also done ad-hoc either in the query to the database or as a data preprocessing step before loading them to VISIR-DB.

Third, we are also aware that the construction and interpretation of both the circuits and the work indicators is not trivial. Different features and helper tools are being thought to overcome these issues.

Fourth, the whole process needs to be streamlined to facilitate quick feedback to the instructors. In this sense, there is an on-going project to add a function to export a report

from VISIR-DB which could provide additional guidance to the instructors in interpreting the analyses of the traces.

And last, we plan to eventually investigate providing real-time feedback to the remote lab users, such as different forms of automatic assessment, increasing in this way the usefulness of the LAD.

Besides these essentially technical aspects, exploring the way to convert this information into relevant LA interventions is also on the way. Then, the impact of VISIR-DB on the learning process shall be assessed.

Beyond VISIR-DB, our research provides valuable insights for designing LADs for other remote labs. From our experience, it is important to record fine-grained logs of users' work. This information must be processed to ensure that equivalent actions produce comparable outcomes; mirroring the normalization and simplification processes used in VISIR-DB. Additionally, comparing users' activity with a priori expected outcomes serves as an effective method for assessing individual performance. Finally, summarizing the results in appropriate visualizations is critical to facilitate the interpretation of the collected data.

Supplementary Information The online version contains supplementary material available at <https://doi.org/10.1007/s10758-024-09752-3>.

Funding Open Access funding provided thanks to the CRUE-CSIC agreement with Springer Nature. This work was supported in part by Aristos Campus Mundus under Grant 2021_19, Grant 2022_27 and Grant 2023_18.

Data Availability Both versions of VISIR-DB, stable-19.04 and stable-21.12, are available at <https://github.com/vanessaserrano/visirTR>.

Declarations

Conflict of interest No conflicts to declare.

Ethical Approval Since data collection is automated and embedded in the standard use of the VISIR remote lab, and the research data are fully anonymized and do not include any personal information, the authors understand that formal approvals were not required according to the ethics guidelines at their institutions.

Open Access This article is licensed under a Creative Commons Attribution 4.0 International License, which permits use, sharing, adaptation, distribution and reproduction in any medium or format, as long as you give appropriate credit to the original author(s) and the source, provide a link to the Creative Commons licence, and indicate if changes were made. The images or other third party material in this article are included in the article's Creative Commons licence, unless indicated otherwise in a credit line to the material. If material is not included in the article's Creative Commons licence and your intended use is not permitted by statutory regulation or exceeds the permitted use, you will need to obtain permission directly from the copyright holder. To view a copy of this licence, visit <http://creativecommons.org/licenses/by/4.0/>.

References

- Alonso-Fernández, C., Calvo-Morata, A., Freire, M., Martínez-Ortiz, I., & Fernández-Manjón, B. (2019). Applications of data science to game learning analytics data: A systematic literature review. *Computers & Education*, *141*, 103612.
- Behnamnia, N., Kamsin, A., Ismail, M. A. B., & Hayati, S. A. (2023). A review of using digital game-based learning for preschoolers. *Journal of Computers in Education*, *10*(4), 603–636.
- Bile, A. (2022). Development of intellectual and scientific abilities through game-programming in Minecraft. *Education and Information Technologies*, *27*(5), 7241–7256.

- Broisin, J., Venant, R., & Vidal, P. (2017). Awareness and reflection in virtual and remote laboratories: The case of computer education. *International Journal of Technology Enhanced Learning*, 9(2/3), 254–276. <https://doi.org/10.1504/IJTEL.2017.10003509>
- Calvo, M., Carnicer, A., Cuadros, J., Martori, F., Miñarro, A., & Serrano, V. (2019). Computer-assisted assessment in open-ended activities through the analysis of traces: A proof of concept in statistics with R commander. *EURASIA Journal of Mathematics Science and Technology Education*, 15(9), em1743. <https://doi.org/10.29333/ejmste/108456>
- Chang, W., Cheng, J., Allaire, J. J., Xie, Y., & McPherson, J. (2017). shiny: Web application framework for R [Computer software]. URL <http://CRAN.R-project.org/package=shiny> (R package version 1.0.0).
- Chirico, M., Scapolla, A. M., & Bagnasco, A. (2005). A new and open model to share laboratories on the Internet. *IEEE Transactions on Instrumentation and Measurement*, 54(3), 1111–1117. <https://doi.org/10.1109/TIM.2005.847205>
- Conole, G., Gašević, D., Long, P., & Siemens, G. (2011). Message from the LAK 2011 General & Program Chairs. In G. Conole, & D. Gašević (Eds.), *Proceedings of the 1st International Conference on Learning Analytics and Knowledge Association for Computing Machinery* (ACM).
- Cuadros, J., Serrano, V., Lluch, F., García-Zubía, J., & Hernández-Jayo, U. (2021). Mapping VISIR Circuits for Computer-assisted Assessment. In *2021 World Engineering Education Forum/Global Engineering Education Deans Council (WEEF/GEDC)*. IEEE, 524–527. <https://doi.org/10.1109/WEEF/GEDC53299.2021.9657349>
- Dormido Bencomo, S. (2002). Control learning: Present and future. *IFAC Proceedings Volumes*, 35(1), 71–93.
- Fidalgo, A. V., Alves, G. R., Marques, M. A., Viegas, M. C., Costa-Lobo, M. C., Hernández-Jayo, U., García-Zubía, J., & Gustavsson, I. (2014). Adapting remote labs to learning scenarios: Case studies using VISIR and remotElectLab. *IEEE Revista Iberoamericana De Tecnologías Del Aprendizaje*, 9(1), 33–39. <https://doi.org/10.1109/RITA.2014.2302071>
- Fischer, C., Pardos, Z. A., Baker, R. S., Williams, J. J., Smyth, P., Yu, R., Slater, S., Baker, R., & Warschauer, M. (2020). Mining big data in education: Affordances and challenges. *Review of Research in Education*, 44(1), 130–160. <https://doi.org/10.3102/0091732X20903304>
- García-Zubía, J., Alves, G. R., Hernández-Jayo, U., Cuadros, J., Serrano, V., & Fidalgo, A. (2019a). A framework for interpreting experimental errors in VISIR. In *2019 5th Experiment International Conference (exp. at'19)*, 31–35. <https://doi.org/10.1109/EXPAT.2019.8876568>
- García-Zubía, J., Cuadros, J., Serrano, V., Hernández-Jayo, U., Angulo-Martínez, I., Villar, A., Orduña, P., & Alves, G. (2019b). Dashboard for the VISIR remote lab. In *2019 5th Experiment International Conference (exp. at'19)*, 42–46. <https://doi.org/10.1109/expat.2019.8876527>
- Gonçalves, A. L., Carlos, L., Alves, G. R., Silva, J. B. D., & Alves, J. B. (2018). Learning Analytics and Recommender Systems toward Remote Experimentation. *Learning Analytics Summer Institute (LASI)*.
- Gustavsson, I. (2003). A remote access laboratory for electrical circuit experiments. *International Journal of Engineering Education*, 19(3), 409–419.
- Gustavsson, I., Nilsson, K., Zackrisson, J., García-Zubía, J., Hernández-Jayo, U., Nafalski, A., Nedic, Z., Gol, O., Machotka, J., Pettersson, M. I., Lago, T., & Hakansson, L. (2009). On objectives of instructional laboratories, individual assessment, and use of collaborative remote laboratories. *IEEE Transactions on Learning Technologies*, 2(4), 263–274. <https://doi.org/10.1109/TLT.2009.42>
- Heflin, H., Shewmaker, J., & Nguyen, J. (2017). Impact of mobile technology on student attitudes, engagement, and learning. *Computers & Education*, 107, 91–99.
- Hernandez-de-Menendez, M., Morales-Menendez, R., Escobar, C. A., & Arinez, J. (2021). Biometric applications in education. *International Journal on Interactive Design and Manufacturing (IJ-DeM)*, 15, 365–380.
- Hernández-Jayo, U., & García-Zubía, J. (2016). Remote measurement and instrumentation laboratory for training in real analog electronic experiments. *Measurement*, 82, 123–134. <https://doi.org/10.1016/j.measurement.2015.12.017>
- Jivet, I., Scheffel, M., Drachsler, H., & Specht, M. (2017). Awareness is not enough: Pitfalls of learning analytics dashboards in the educational practice. In *European conference on technology enhanced learning*. Springer, Cham, 82–96. https://doi.org/10.1007/978-3-319-66610-5_7
- Leitner, P., Ebner, M., & Ebner, M. (2019). Learning analytics challenges to overcome in higher education institutions. In D. Ifenthaler, D.-K. Mah, & J.Y.-K. Yau (Eds.), *Utilizing learning analytics to support study success* (pp. 91–104). Cham: Springer. https://doi.org/10.1007/978-3-319-64792-0_6
- Liu, M., Lee, J., Kang, J., & Liu, S. (2016). What we can learn from the data: A multiple-case study examining behavior patterns by students with different characteristics in using a serious game. *Technology, Knowledge and Learning*, 21, 33–57.

- Matcha, W., Gašević, D., & Pardo, A. (2019). A systematic review of empirical studies on learning analytics dashboards: A self-regulated learning perspective. *IEEE Transactions on Learning Technologies*, 13(2), 226–245. <https://doi.org/10.1109/TLT.2019.2916802>
- McFarland, D. A., Khanna, S., Domingue, B. W., & Pardos, Z. A. (2021). Education Data Science: Past, Present. *Future. AERA Open*, 7(1), 1–12. <https://doi.org/10.1177/23328584211052055>
- Mendonça, L. N., Maçaneiro, M., Alves, G. R., Pires, D. S., García-Zubía, J., Cuadros, J., & Serrano, V. (2020). Classification of experimental errors done in VISIR with simple alternated current circuits. In *2020 IEEE Global Engineering Education Conference (EDUCON)*. IEEE, 1568–1572. <https://doi.org/10.1109/EDUCON45650.2020.9125340>
- Nedic, Z., & Machotka, J. (2007). Remote Laboratory NetLab for Effective Teaching of 1st Year Engineering Students. *International Journal of Online Engineering*, 3(3), 1–6. <https://doi.org/10.3991/ijoe.v3i3.436>
- Nguyen, H., Campos, F., & Ahn, J. (2021). Discovering Generative Uncertainty in Learning Analytics Dashboards. In M. Sahin & D. Ifenthaler (Eds.), *Visualizations and Dashboards for Learning Analytics* (pp. 457–475). Cham: Springer. https://doi.org/10.1007/978-3-030-81222-5_21
- Orduña, P., García-Zubía, J., Rodríguez-Gil, L., Angulo, I., Hernández-Jayo, U., Dziabenko, O., & López-de-Ipiña, D. (2018). The weblab-deusto remote laboratory management system architecture: achieving scalability, interoperability, and federation of remote experimentation. In M. E. Auer, A. K. M. Azad, A. Edwards, & T. De Jong (Eds.), *Cyber-Physical Laboratories in Engineering and Science Education* (pp. 17–42). Cham: Springer.
- Orduña, P., Almeida, A., López-de-Ipiña, D., & García-Zubía, J. (2014, April). Learning analytics on federated remote laboratories: Tips and techniques. In *2014 IEEE Global Engineering Education Conference (EDUCON)*. IEEE, 299–305. <https://doi.org/10.1109/EDUCON.2014.6826107>
- Park, Y., & Jo, I. H. (2015). Development of the learning analytics dashboard to support students' learning performance. *Journal of Universal Computer Science*, 21(1), 110. <https://doi.org/10.3217/jucs-021-01-0110>
- Pozdniakov, S., Martinez-Maldonado, R., Tsai, Y. S., Cukurova, M., Bartindale, T., Chen, P., Marshall, R., Richardson, D., & Gasevic, D. (2022). The Question-driven Dashboard: How Can We Design Analytics Interfaces Aligned to Teachers' Inquiry? In *LAK22: 12th International Learning Analytics and Knowledge Conference*, 175–185. <https://doi.org/10.1145/3506860.3506885>
- Romero, C., & Ventura, S. (2020). Educational data mining and learning analytics: An updated survey. *Wiley Interdisciplinary Reviews: Data Mining and Knowledge Discovery*, 10(3), e1355. <https://doi.org/10.1002/widm.1355>
- Salcines-Talledo, I., González-Fernández, N., Díaz-Herrera, L., & Area-Moreira, M. (2022). Smartphones in Higher Education. *A Longitudinal Qualitative Study. Comunicar*, 30(72), 115–127.
- Schwendimann, B. A., Rodríguez-Triana, M. J., Vozniuk, A., Prieto, L. P., Boroujeni, M. S., Holzer, A., Gillet, D., & Dillenbourg, P. (2017). Perceiving learning at a glance: A systematic literature review of learning dashboard research. *IEEE Transactions on Learning Technologies*, 10(1), 30–41. <https://doi.org/10.1109/TLT.2016.2599522>
- Serrano, V., Cuadros, J., García-Zubía, J., Hernández-Jayo, U., & Mompó, L. (2018). Design and Development of a Dashboard for the Visualization and Assessment of Students Work in a Remote Lab. In *IEEE VIS18*.
- Siemens, G., & Long, P. (2011). Penetrating the fog: Analytics in learning and education. *EDUCAUSE Review*, 46(5), 30.
- Susnjak, T., Ramaswami, G. S., & Mathrani, A. (2022). Learning analytics dashboard: A tool for providing actionable insights to learners. *International Journal of Educational Technology in Higher Education*, 19(1), 1–23. <https://doi.org/10.1186/s41239-021-00313-7>
- Tabuenca, B., Serrano-Iglesias, S., Carruana Martín, A., Villa-Torrano, C., Dimitriadis, Y., Asensio-Pérez, J. I., Alario-Hoyos, C., Gómez-Sánchez, E., Bote-Lorenzo, M. L., Martínez-Monés, A., & Kloos, C. D. (2021). Affordances and core functions of smart learning environments: A systematic literature review. *IEEE Transactions on Learning Technologies*, 14(2), 129–145. <https://doi.org/10.1109/TLT.2021.306794>

Authors and Affiliations

Vanessa Serrano^{1,2}  · **Jordi Cuadros**¹ · **Laura Fernández-Ruano**¹ ·
Javier García-Zubía³ · **Unai Hernández-Jayo**³ · **Francesc Lluch**¹

✉ Vanessa Serrano
vanessa.serrano@urv.cat

Jordi Cuadros
jordi.cuadros@iqs.url.edu

Laura Fernández-Ruano
laura.fernandez@iqs.url.edu

Javier García-Zubía
zubia@deusto.es

Unai Hernández-Jayo
unai.hernandez@deusto.es

Francesc Lluch
francesclluce@iqs.url.edu

¹ IQS Univ. Ramon Llull, Via Augusta 390, 08017 Barcelona, Spain

² Education and Psychology Sciences Faculty, Univ. Rovira I Virgili, Carretera de Valls S/N, 43007 Tarragona, Spain

³ Faculty of Engineering, University of Deusto, Avda. Universidades 24, 48007 Bilbao, Spain